



Repair of Mindray Brand Syringe Pump Type Benfusion SP1

Gunyono Gunyono

Sekolah Tinggi Ilmu Kesehatan Semarang

Imam Tri Harsoyo

Sekolah Tinggi Ilmu Kesehatan Semarang

Anggiat Winner Os

Sekolah Tinggi Ilmu Kesehatan Semarang

Jl. Colonel Warsito Sugiarto KM. 2.5 Gunungpati Semarang 50222

Corresponding author: writer.gunyono21@email.com

Abstract . Syringe pump is a tool used to inject medicinal liquids into the human body with high precision using millimeters per hour (ml/h). The Mindray brand syringe pump type Benfusion SP1 had a fatal damage condition because the system experienced a system failure, so it could not function properly. The syringe pump cannot detect the syringe size that has been set because the control system does not work. Repair of the syringe pump was carried out by measuring using a multimeter at the specified measurement point. The syringe pump was successfully repaired by replacing the potentiometer component. After making recommendations, the flowrate and occlusion function tests were carried out. From the results of the flowrate function test, the percentage values were obtained, namely 10ml/h= 3.48%, 50ml/h= 1.19%, 100ml/h= 3.48%. and with occlusion experiments with a setting point of 100ml/h, an average value of 523mmHg or 10.113251 psi was easily obtained. From the results above it can be concluded that the tool is still suitable for use because it is still within the tolerance limit of 10% so that the tool can be used again.

Keywords : Syrene Pump, Potentionmeter, Function Test

BACKGROUND

Hospitals are very complex systems so it is difficult to control patients. There are many cases of malpractice and along with developments in technology in the medical field, society's demands for life safety are increasing which are related to the reputation of hospitals. This causes the need to improve quality in the medical field. One very important and basic medical tool is a syringe. Syringes are used as medical tools to make it easier for medicinal fluids to enter the body. For patients who require extra and intensive treatment, a device is needed that can control the dose, volume of drug use and *flow rate* of the drug to be injected. Flow rate is the amount or volume of fluid flowing measured per unit time (Hikmah, Rancang bangun syringe pump berbasis mikrokontroler Atmega8535 dilengkapi detektor okulsi, 2013).

Pum syringes are often heard in hospitals or clinics, where they have quite a vital function. This tool is often used in certain conditions, such as treatment in the ICU (*Intensive Care Unit*), treatment of patients in critical condition in the ER (Emergency Room), as well as patients undergoing surgery and so on. If defined freely, a syringe pump is a type of medical equipment or medical device that is used to regulate the process of injecting liquid medicine

into a patient's body at a certain quantity and time. So, the syringe pump can be used in conjunction with another tool, namely a disposable syringe or what is often called a syringe (Nur, 2018).

A syringe pump is a tool used to inject medicinal fluids into the human body with high precision using volume units of millimeters per hour (ml/h). This tool has a drive, namely a DC motor to provide pressure to the syringe pump which has been set and this tool can also use a microprocessor electronic circuit so that you can know the amount of fluid that has entered the patient's body which appears on the LCD screen and sounds an alarm (anggriani, 2019).

The motor drive will cause the thread to advance so that it pushes the plunger (injection pusher) and the injection process begins to occur. Overall, the syringe pump system consists of a plunger, a motor, a pump mechanism, a pump mechanism controller, and an alarm. The pump mechanism uses a force that pushes the plunger so that the medication fluid in the tube is pushed towards the patient's blood vessels. A problem that often arises when using a syringe pump is occlusion (blockage) during the pump mechanism. Continuous use of a syringe pump can cause occlusion, which causes the drug fluid that enters the body to not flow consistently and creates large pressure on the syringe and the flow of fluid, which if left unchecked will result in swelling (Hikmah, 2016).

The syringe pump has a good level of security so that users usually use an alarm to find out the condition of the syringe pump while it is working. The syringe pump has an alarm sound, each alarm has a different sound. The first is an occlusion alarm which functions to provide an alarm sound and stop the pump system when a blood vessel blockage occurs in the patient. Second, the delivery limit alarm is to provide a limit on the amount of fluid to be given to the patient. If the amount of fluid given has been reached, an alarm will sound and the device will stop pumping. Third, the nearly empty alarm functions to provide a signal when the fluid given to the patient will soon run out (Laia, 2022).

The Mindray brand syringe pump type Benefusion SP1 had a fatal damage condition because the device experienced a system failure, so it could not detect the specified size of the syringe or syringe. As a result, the syringe pump cannot function properly, the syringe pump cannot detect the specified syringe size. Because there was damage to one of the components, namely the potentiometer, the tool could not function properly and a system error warning appeared on the LCD screen. Based on the damage above, the researcher will conduct research aimed at repairing the Mindray type Benefusion SP1 syringe pump.

THEORETICAL STUDY

The following are several discussions about syringe pumps that have been carried out previously. namely the first referring to the final assignment of STIKES Semarang students, a syringe pump is an electromedical equipment that functions to administer medication through a blood vessel, by pushing the rod of the injection device so that it can release a flow range from microliters to millimeters per minute periodically with high precision so that this does not happen. errors in administering doses to patients. However, with the damaged syringe pump, the activities and activities of medical personnel were slightly hampered, therefore the author took the initiative to repair the syringe pump with the ACMA brand type AF-330 so that it could be used again. For damage to the syringe pump on the stepper motor driver circuit board, damage to the optocoupler component can cause the motor self check failed indicator so that it cannot operate. Analysis of syringe pump damage based on troubleshooting on the syringe pump tool. Repair the syringe pump by replacing damaged components in the optocoupler sensor circuit. After repairs have been carried out by replacing components, the syringe pump can function again. After repairs, this tool will be calibrated using the FLUKE IDE 4 PLUS calibrator so that there is no doubt about its accuracy and it can be operated again on the patient safely. (hernawan, 2018).

The syringe pump functions to inject fluids or medication into the patient's body with a high level of accuracy and patients can avoid taking tablet medication by mouth, because the patient is unconscious or has difficulty taking the tablet medication. The importance of this equipment is that if it is damaged it will cause the medical services and rehabilitation process at the hospital to stop. Efforts made to overcome this problem are analyzing and repairing damaged syringe pumps. Damage analysis when the syringe pump is turned on, error code 3 appears on the display based on the troubleshooting in the Terumo STC-527 service manual book with a description of the motor rotation error. Checks were carried out on the power supply output, control board, and stepper motor driver circuit. From the stepper motor driver output, the value was zero. In this way, it is known that there is damage to the optocoupler sensor component, so repairs are carried out by replacing the optocoupler sensor. After repairs have been carried out by replacing components, the next calibration tool uses ESA 612 FLUKE BRAND to check the electricity on the syringe pump and IDA 4 PLUS FLUKE Brand to set the flow rate measurement values of 5 ml/h, 50 ml/h, 100 ml/h, 150 ml /h and Occlusion with a value of 100ml/h. From the flow rate test results, the values were 4.97 ml/h, 49.30 ml/h, 99.64 ml/h, 149.97 ml/h and Occlusion with an average value of 9.46 Psi. The calibration results for the flow rate parameter are still within the tolerance limit, namely 10%, and the Occlusion

parameter is still within the standard limit, namely 9.5 Psi. So the tool is declared fit for use because it is still within tolerance (paramartha, 2020).

A syringe pump is a type of health equipment that functions to inject medicinal fluids into the patient's body for a certain period of time on a regular basis. The syringe pump cannot function properly as it should. Repair of the syringe pump equipment, the damage was to the fuse leaded NBK 190609-JP1021B5A which was broken and the Elco 100uf 25V capacitor component which was burned. After replacing the NBK 190609-JP1021B 5A leaded fuse and its 1000uf 25V capacitor which did not exceed the tolerance, it was said that the voltage was appropriate. These results are in accordance with the syringe pump specifications and show that the ACMAFUSION AF-330 brand syringe pump is still safe to use. After the repairs were carried out, the author carried out a functional test on the syringe pump using an IDA (infusion device analyzer) tool and obtained the results for setting 10 ml/h, getting an average result of 9.63, for setting 50 ml/h, getting an average result. 49.84. From the results of the functional test, it can be said that the tool is still suitable for use and the tool is in normal condition again and the tool can be used again. (Mutoharoh, 2022).

A syringe pump is a medical device that is used to inject medicinal fluid into the patient's body at a certain time and in a certain dose, where the time and dose are regulated by the user. The Braun brand syringe pump is damaged, the damage to the device is an error alarm 045 or the potentiometer fails to function. Repair the alay syringe pump by checking the resistance value of the potentiometer at the specified measurement point. The checking results show that the potentiometer is not functioning properly. Repair the syringe pump by replacing the potentiometer. After carrying out repairs, a functional test of the tool was carried out using a measuring cup with a flow rate setting point of 10 ml/h, 20 ml/h, 30 ml/h, 40 ml/h, 50 ml/h, 100 ml/h. From the results of the flow rate function test, the percentage error value for each setting point is 4%, 2%, 1.3%, 1.75%, 0.8%, 0.4%. From the test results, it was concluded that the Braun brand syringe pump could be used because it was still within the 10% tolerance limit. So it can be concluded that the repair has been successful (Baharudin, 2023).

A syringe pump is a type of medical equipment that functions to inject medicinal fluids into the patient's body for a certain period of time on a regular basis. The syringe pump cannot function properly. The damage that occurs to the syringe pump is that it cannot detect injections. So it requires improvements to the syringe pump so that it can detect injections according to their function. Repairs to the syringe pump are carried out by measuring using a multimeter at the specified measurement points. The syringe pump was successfully repaired by replacing the Optocoupler sensor component. The value obtained from measurements after

improvements at TP 1 (input from the PLN grid) had an error of 0%. TP2 (voltage on battery) is 0.5%. TP3 (power supply output) is 0%. TP4 (sensor input) is 3 VDC. TP5 (sensor input) is 3.3%. The tool used for functional testing using a measuring cup and stopwatch obtained an average of 9.38 ml/h at a setting of 100 ml/h. At a setting of 200 ml/h, an average of 19.93 ml/h was obtained. And at a setting of 50 ml/h, you get an average of 49.85 ml/h. So it was concluded that the tool was functioning well because it was still within the tolerance limit of 10% (Farid, 2023).

RESEARCH METHODS

The type of research carried out by the author is applied research. The applied method is an investigation carried out using scientific knowledge, the aim of which is to solve a problem that occurs in the field directly and find the right solution to overcome the problem, so that it can be resolved correctly and quickly. When the author conducted the research, it was from March to May 2024. Research regarding the repair of the Mindray Brand Syringe Pump Type Benfusion SP1 took place at the Semarang College of Health Sciences Campus. In this research the author improved the syringe pump, this tool uses a potentiometer to detect the syringe or syringe, a stepper motor to control the precision movement of the syringe piston.

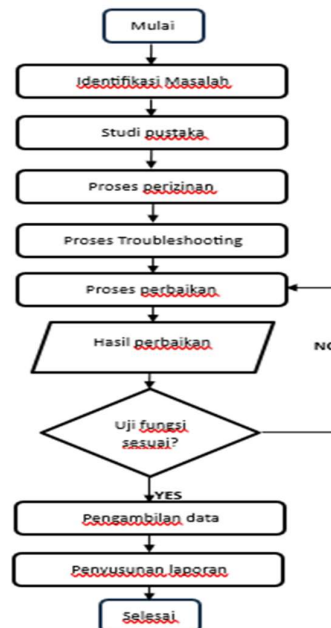

Figure 1. Research flowchart

1. Block diagram

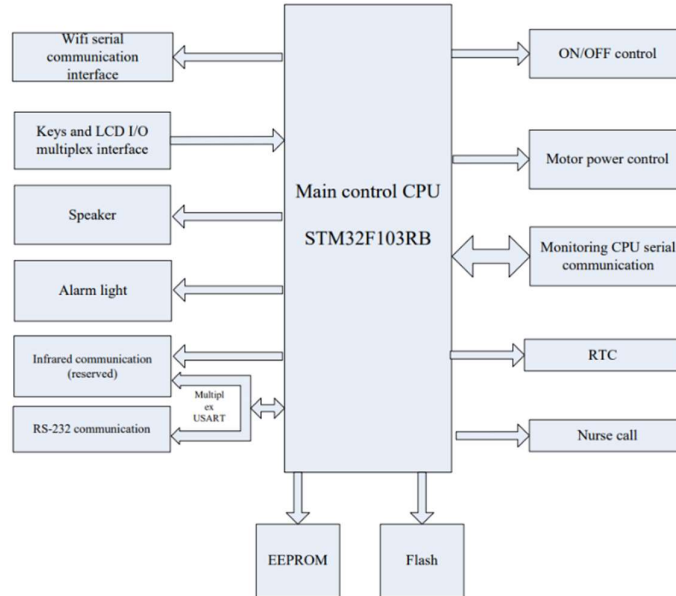

Figure 2. Block diagram of the tool

Information:

The main control section is responsible for LCD display driver, speaker alarm circuit, nurse call, key management, CPU UART communication monitoring and other functions. The main control CPU is equipped with the optional cortex M3 core chip STM32F103RBT6 (U5), and uses the intel 8080 system bus interface as the display driver. The speaker alarm circuit consists of a PWM wave modulation circuit and an amplifier circuit: Q13, U13, and peripheral RC form a PWM wave modulation circuit: U4 is a sound amplifier chip based on a +5 V power supply. Nurse call is an additional function, which is connected to the home alarm system sick through a dedicated nurse call cable: Q2, Q8, and peripheral RC form the nurse call circuit U16 is an EEPROM with an I2C interface to store information such as historical records and calibration data. U7 is Nor flash with SPI interface to store drug library, language library, and image resources and etc. X1 is a 32.768 KHz passive crystal oscillator, providing the RTC module, the main control CPU with a clock signal. U19 is an RS232 level converter chip. The main control CPU is responsible for switch control and motor power protection when a single fault occurs, while the monitoring CPU is responsible for monitoring the battery charge status, detecting the power status of various modules, controlling the battery indicator, and communicating with the main control module CPU via the serial port. After being triggered by the switch button of the key board, the main control CPU and monitoring CPU simultaneously emit an ON lock signal and a module power enable signal to turn on the VCC, VDD, and VMM

exits, so that all detect the OFF signal, the main control CPU notifies the monitoring CPU to cancel the ON lock signal through the serial port, and finally the equipment is turned off by the main control CPU. The battery charge-discharge management circuit uses BQ24103RHLR, with OFF- and ON-mode charging currents designed for 650 ± 50 mA (single battery charging time is not more than 6 hours, while double battery charging time is not more than 12 hours). The battery is designed to be fully charged at a voltage of 8.1 ± 0.2 V. When the battery voltage is too low, the AC power supply and the external DC power supply are disconnected, the standby sound-light alarm circuit triggers the buzzer to sound at a frequency of 2.37 Hz \pm 0.5 V, and simultaneously actuates red alarm light to stay on. When the monitoring CPU detects unusual VDD power or abnormal communication with the main control module CPU, the buzzer sounds and the stepper motor power is then turned off.

2. Test tool function

At this stage the author carried out function tests and collected data after the syringe pump had been repaired. The function test is carried out to determine that the tool can function properly and can be used again by the patient. The function test of the syringe pump is carried out using two parameters, namely speed measurement.

flow or flow rate (ml/h) and stability test or occlusion test (psi). Measurements can be done in two ways, namely using an IDA (infusion device analyzer) or manually using a measuring cup and stopwatch. In this measurement the author used a manual method using a measuring cup and stopwatch.



Figure 3. Tool testing

In the picture above, flow rate and occlusion measurements are taken. In pictures one and two are the flow rate measurement stages (ml/h). And the third picture is the occlusion measurement.

RESULTS AND DISCUSSION

1. Flow rate testing

Flow rate testing aims to ensure that the tool can flow fluid at the correct and consistent speed according to the desired settings. The test was carried out three times with volume settings of 10ml/h, 50ml/h, and 100ml/h, with a tolerance value of $\pm 10\%$.

Tabel Hasil uji fungsi *flow rate* 10 ml/h

Setting Flowrate	Hasil Pengukuran		Waktu	Hasil Perhitungan
	Syringe	Gelas Ukur		
10 ml/h	4,9	5,2	30 Menit	9,8 ml/h
	5	5,2		10 ml/h
	4,9	5,2		9,8 ml/h

Tabel Hasil uji fungsi *flow rate* 50 ml/h

Setting Flowrate	Hasil Pengukuran		Waktu	Hasil Perhitungan
	Syringe	Gelas Ukur		
50 ml/h	8,3	8,4	10 Menit	49,8 ml/h
	8,3	8,4		49,8 ml/h
	8,3	8,4		49,8 ml/h

Tabel Hasil uji fungsi *flow rate* 100 ml/h

Setting Flowrate	Hasil Pengukuran		Waktu	Hasil Perhitungan
	Syringe	Gelas Ukur		
100 ml/h	8,3	8,6	5 Menit	99,6 ml/h
	8,3	8,6		99,6 ml/h
	8,3	8,6		99,6 ml/h

2. Occlusion Testing (blockage)

Occlusion or blockage testing aims to ensure the device works well and is safe for use in infusion of drugs or fluids into patients. The test is carried out 3 times with a volume setting of 100 ml/h.

Tabel hasil pengukuran Occlusion	
Syringe	PSI
523 mmHg	10,113251
523 mmHg	10,113251
521 mmHg	10,074577

CONCLUSIONS AND RECOMMENDATIONS

After completing the repair of the Mindray brand Benefusion SP1 syringe pump which was damaged and indicated by the appearance of a "system error". The error system on the LCD screen, starting from observations in the field, literature study, planning, experimentation, data collection and data analysis, the author draws conclusions about the function test of the Mindray brand syringe pump type Benefusion SP1, namely measuring the flow rate and occlusion of the tool. The results of the functional test show that the syringe pump is functioning properly and correctly so that it can be used again. Experimenting with a volume setting of 10 ml/h produces an average value of 4.9 ml/h, error = 5.67%, then with a volume setting of 50 ml/h, an average value of 8.3 ml/h, error = 1, is obtained. 19%, then next with a volume setting of 100 ml/h there is an average value of 8.3 ml/h error = 3.48% then finally the occlusion experiment with a volume setting value of 100 ml/h gets an average value of 523 mmHg or 10.113251 psi. From the two experiments above, it can be concluded that the tool is still suitable for use because the values obtained are still within the tolerance limit of $\pm 10\%$. From the above research that has been carried out, there is a suggestion from the author, namely the importance of regularly checking the equipment so that it remains in good and proper condition, thereby reducing the occurrence of damage to the equipment. And if damage occurs, immediately carry out damage analysis, repairs and function tests on the syringe pump, namely flow rate and occlusion by referring to the syringe pump manual book.

REFERENCE LIST

- Anggriani , R. (2019). *FLOW RATE CONTROL SYSTEM ON SYRINGE PUMP* . Bandar Lampung: Digilib Unila.
- Baharudin , RN (2023). *Repair of BBRAUN PERFUSOR COMPACT brand syringe pump* . Semarang: Semarang Stikes.
- Dimas . (2022). *ACMA brand syringe pump repair type AF-330* . Semarang: Semarang Stikes.
- Farid, M. (2023). *Maerk syringe pump repair Mindray type Benfusion SP1* . Semarang: Semarang Stikes.
- Hernawan , TY (2018). *Repair of ACMA brand syringe pump type AF-330* . Semarang: Semarang Stikes.
- Wisdom, NF (2013). Design build a syringe pump based Atmega8535 microcontroller. *Journal Physics and Applied Science* , 3-6.
- Laia, A. (2022). *SYRINGE PUMP CALIBRATION ANALYSIS* . *Journal PearlElectromedicine* , 5.
- Mutoharoh , C. (2022). *ACMAFUSION AF-330 brand syringe pump repair* . Semarang: Semarang Stikes.
- Nur, B. (2018). Know More Details Regarding Syringe Pump Medical Devices. *PT Glorya Medica Abadi*, 5-7.
- Paramartha , IK (2020). *Repair Terumo brand syringe pump type STC-527* . Semarang: Semarang Stikes.